

DKL - Double Knob Line

Manual Control Unit - Electronic Blower Speed Regulator - A/C and Recirculation Push Buttons
Centralina Manuale - Regolatore Elettronico della Velocità di Ventilazione - Tasti A/C e Ricircolo

Z01.65.021 (12V) - Z01.65.022 (24V)

MECHANICAL DIMENSIONS
DIMENSIONI MECCANICHE

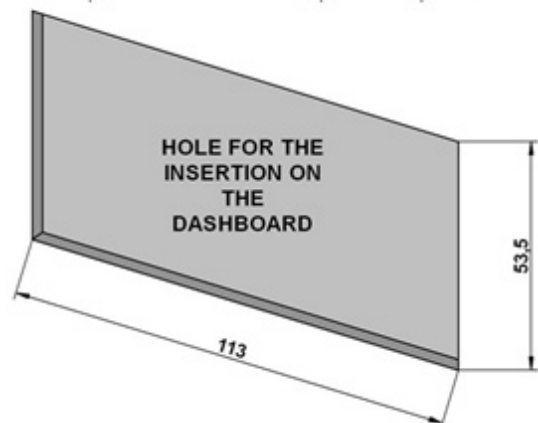
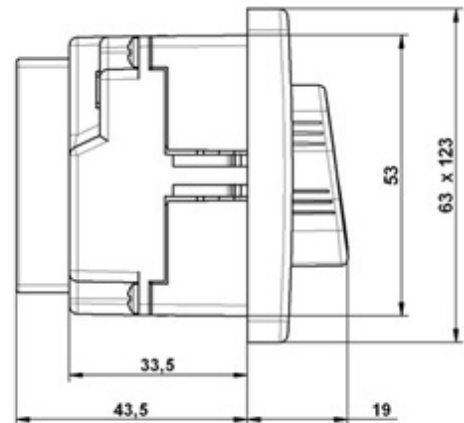
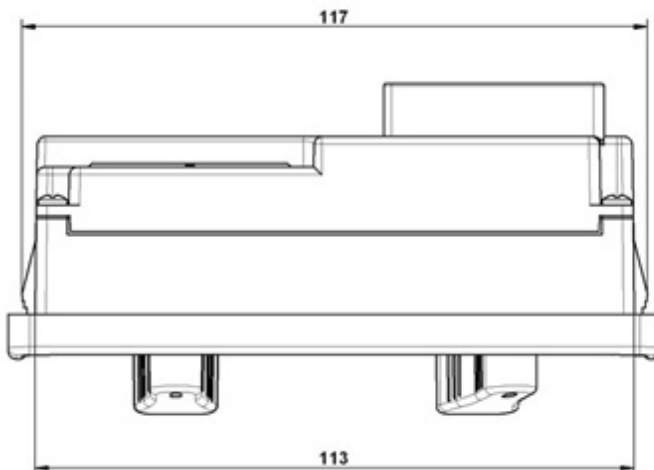
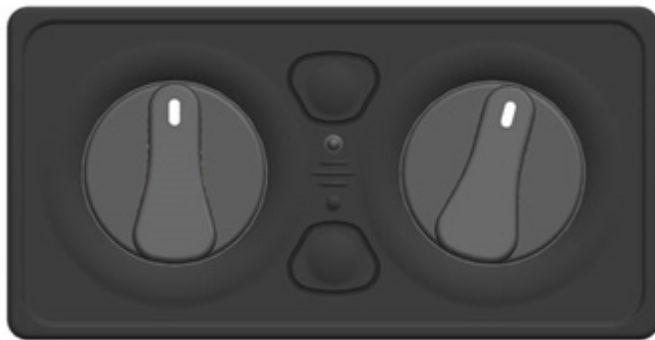

LIST OF MATERIALS
ELENCO COMPONENTI

Description Descrizione	Q.ty Q.tà	P/N 12V	P/N 24V
Control Unit Centralina	01	V02.65.011	V02.65.011
DC Motor Water Valve Kit Kit Valvola Motorizzata	01	61.01.297	61.01.298
Electronic Blower Speed Regulator Kit Kit Regolatore Elettronico della Velocità di Ventilazione	01	Z19.01.135	Z19.01.142
Connector and Pin Kit Kit Pin e Connettori	01	61.01.318	61.01.318
Complete Kit (Relay not included) Kit Completo (Relè non incluso)	01	Z01.65.021	Z01.65.022